

ROOM DOOR

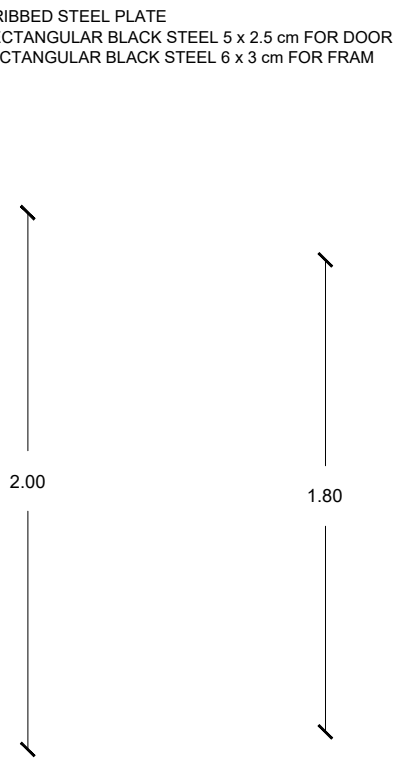

LATRINE DOOR

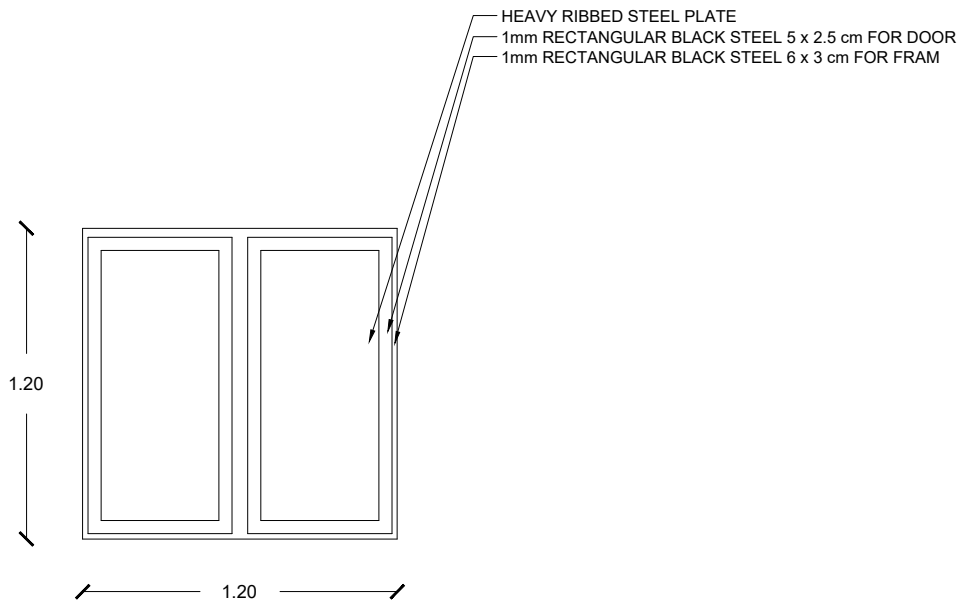

WINDOW

Walls Foundation

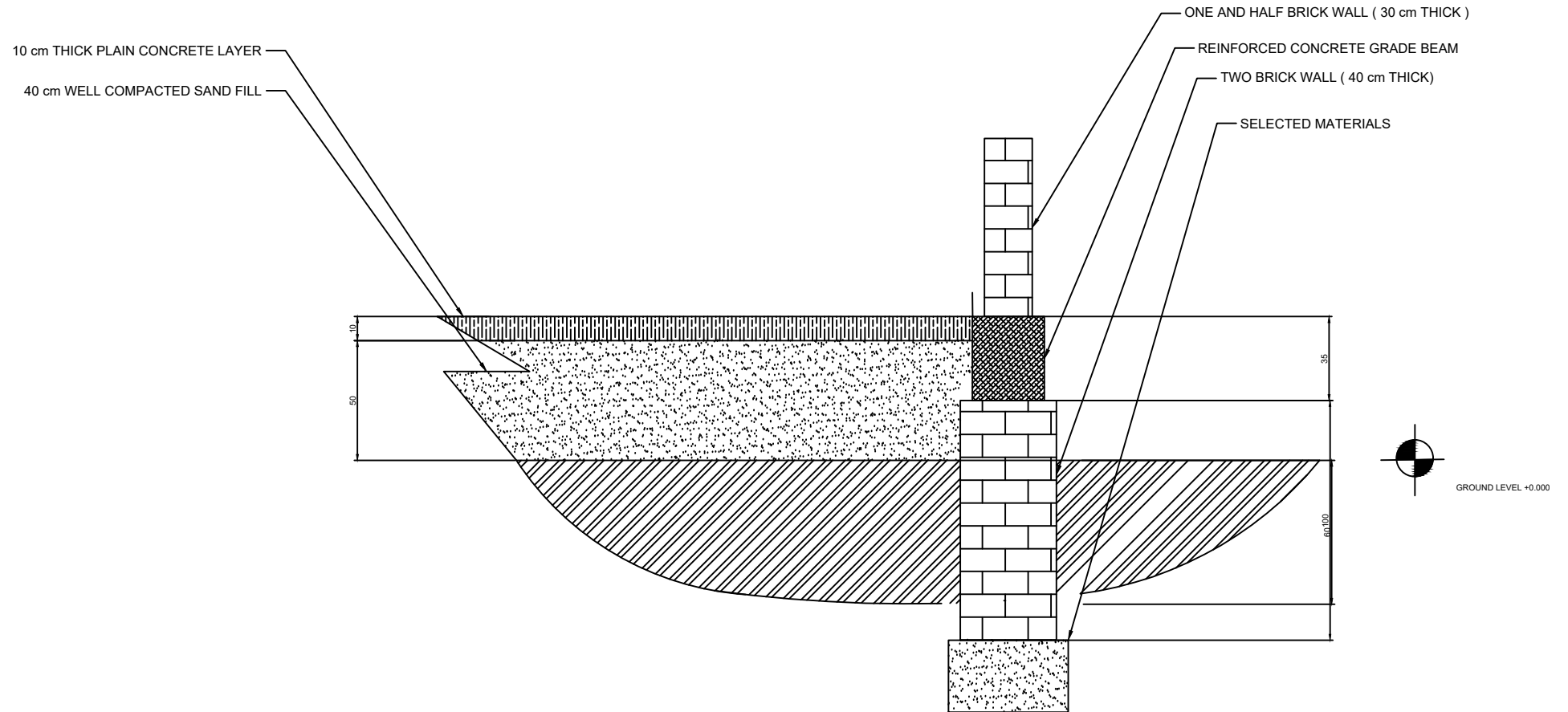

North Elevation 

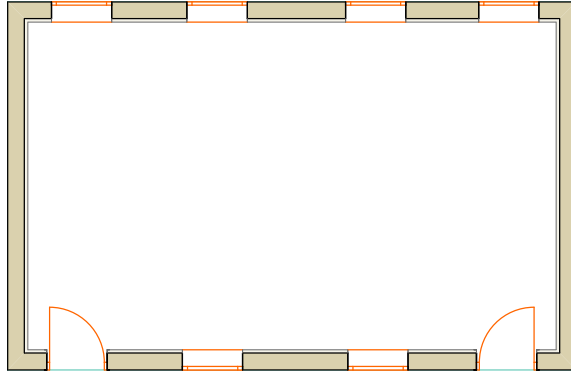
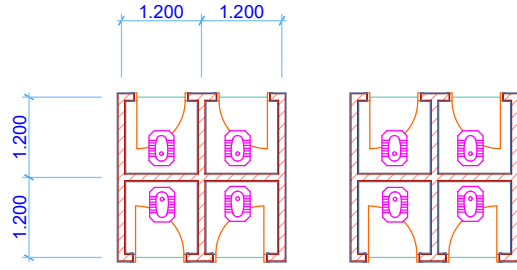

West Elevation 

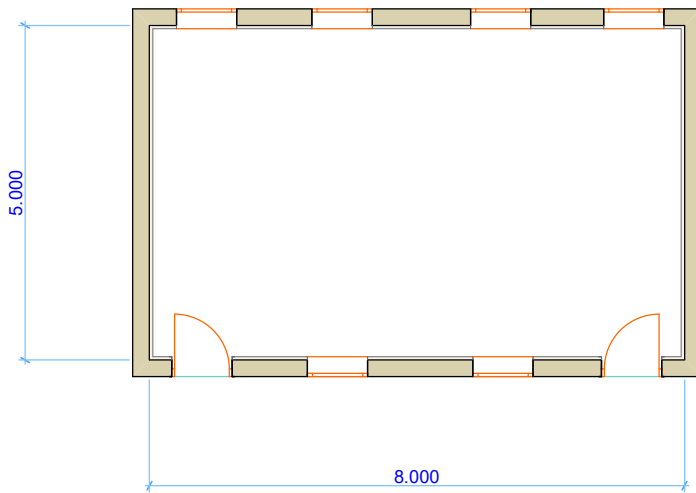

East Elevation 

South Elevation 

North Elevation ▽

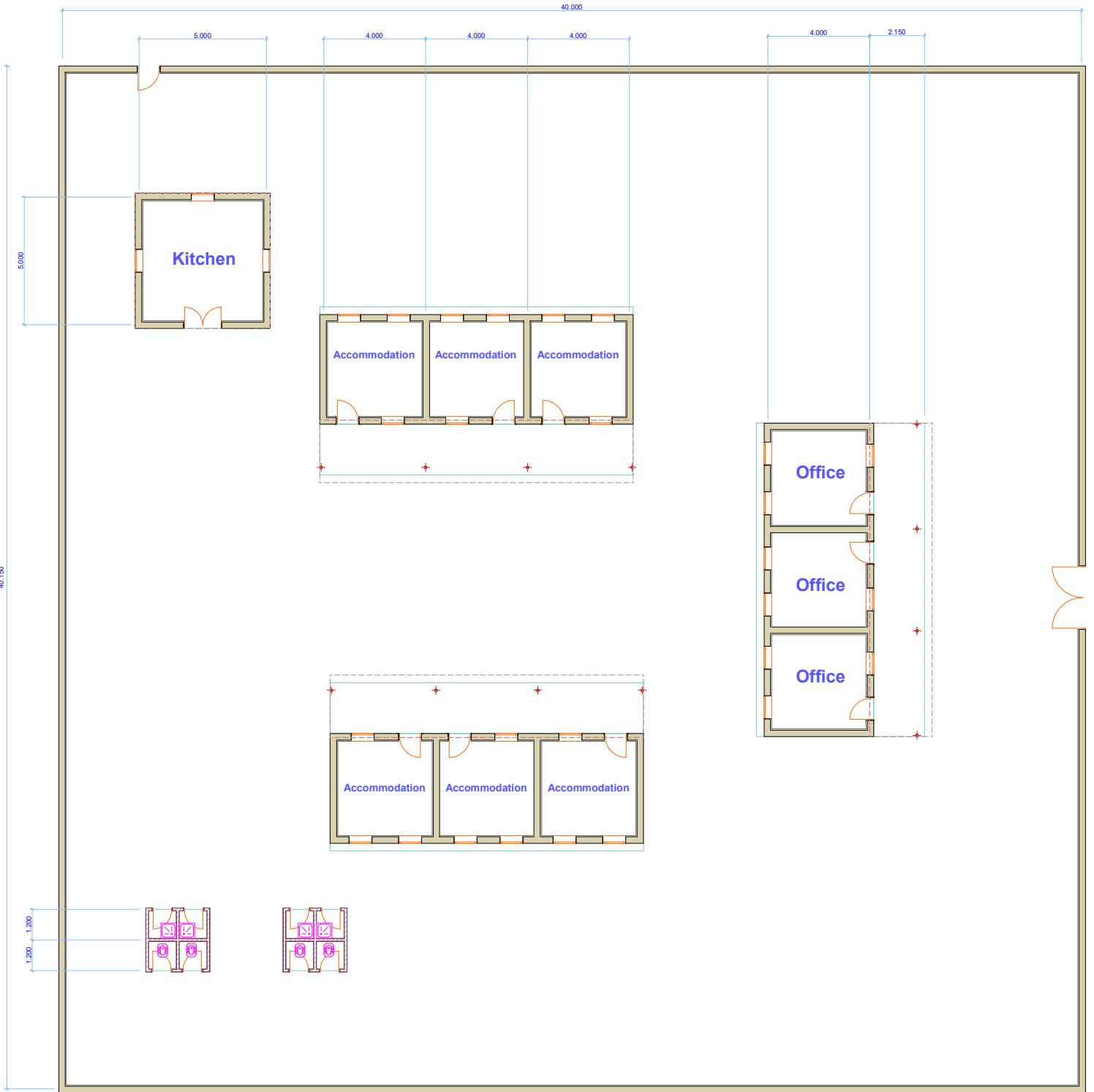

South Elevation ▲

West Elevation
▲

East Elevation
▲

10 x 5 CM HOLLOW BOX STEEL SECTION RAFTER

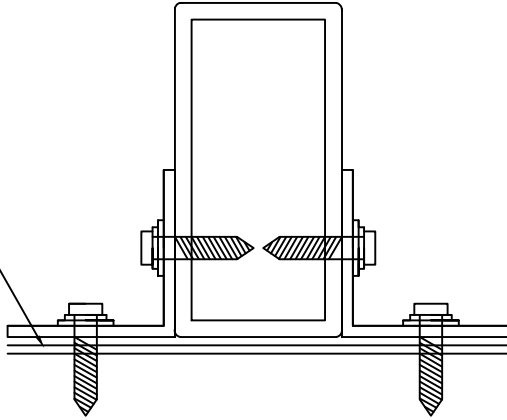

4 x 8 CM HOLLOW BOX STEEL SECTION PURLIN

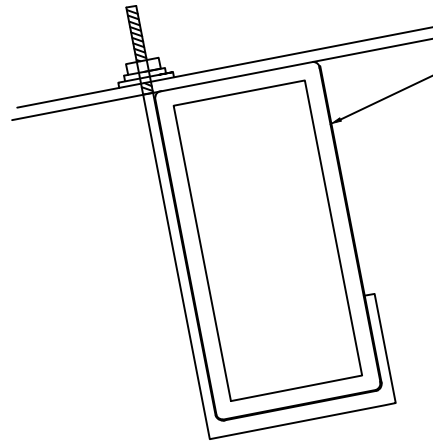

West Elevation

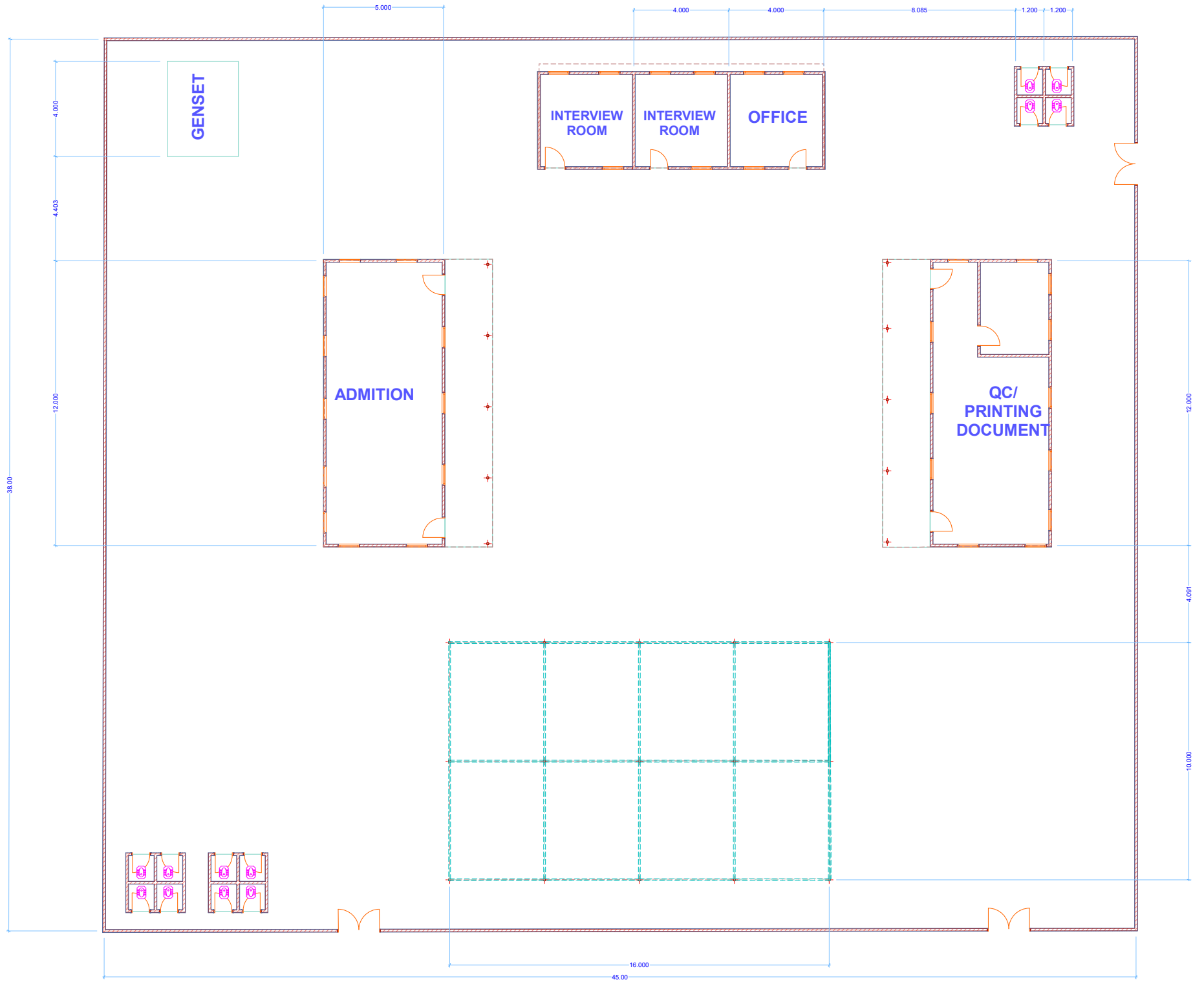

North Elevation

East Elevation

South Elevation

GRADE BEAM DETAIL

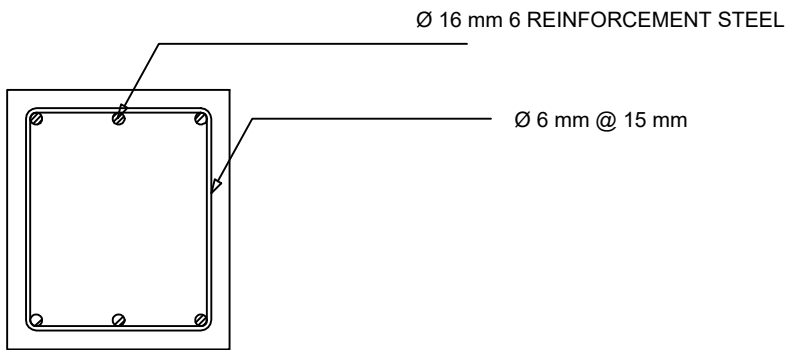

TIE BEAM DETAIL

